





GENERAL NOTES

- 1) PASSLINE OF EQUIPMENT BASED ON 32.5" FROM FLOOR
- 2) CONCRETE FLOOR UNDER SYSTEM TO BE MINIMUM OF 6" THICK
- 3) HORSEPOWER FOR SYSTEM = 32.5 HP, 68 KVA (86 Amps)

CUSTOMER SUPPLIED

- 5a) PRIMARY 460 V / 3 PH. / 60 HZ. [REQ'D @ EACH 
- 5b) AIR REQUIREMENT: 90 PSIG, 5 SCFM MINIMUM FREE AIR [REQ'D @ EACH ] (Without signoscript)
- 5c) AIR REQUIREMENT: 90 PSIG, 42 SCFM MINIMUM FREE AIR [REQ'D @ EACH ] (With signoscript)
- 5d) MOBIL DTE #24 OR AMERICAN #15 HYDRAULIC OIL OR EQUAL [REQ'D @ EACH ] 150 GAL. TOTAL
- 5e) EQUIPMENT TO BE IN AREA OF FINAL INSTALLATION
- 5f) WELDING MACHINE, 2" SQUARE, 2' & 4' LEVELS, TRANSIT, SLEDGE HAMMER, "C" CLAMPS & WRENCHES
- 5g) ANCHOR BOLTS FOR HEAD & INFEED ASSEMBLY, #WS-3454 "RUBOLT" OR EQUAL [24 REQ'D]
- 5h) ANCHOR BOLTS FOR SAFETY LIGHTS #WS-3454 "RUBOLT" OR EQUAL [24 REQ'D]
- 5i) ANCHOR BOLTS FOR LOADERS AND UNLOADERS (IF PURCHASED) #WS-1254 "RUBOLT" OR EQUAL [REQ'D]
- 5j) CUTTING TORCH, 8" PORT-A-POWER & BODY GRINDER
- 5k) (3) MEN TO HELP INSTALL EQUIPMENT: (1) ELECTRICIAN & (2) MAINTENANCE
- 5l) 1-1/2 TON "COME-A-LONG" & 100' STEEL TAPE
- 5m) EQUIPMENT IS SHIPPED IN SUB-ASSEMBLES AND SHOULD BE UNCRATED, ASSEMBLED, POSITIONED AND ROUGH LEVELED BY CUSTOMER. DO NOT BOLT EQUIPMENT TO FLOOR !!!
- 5n) Network/Internet Connection for Data Transfer And Remote Diagnostic And support. [req'd @ Each 

Machine weight ~23,000 lbs

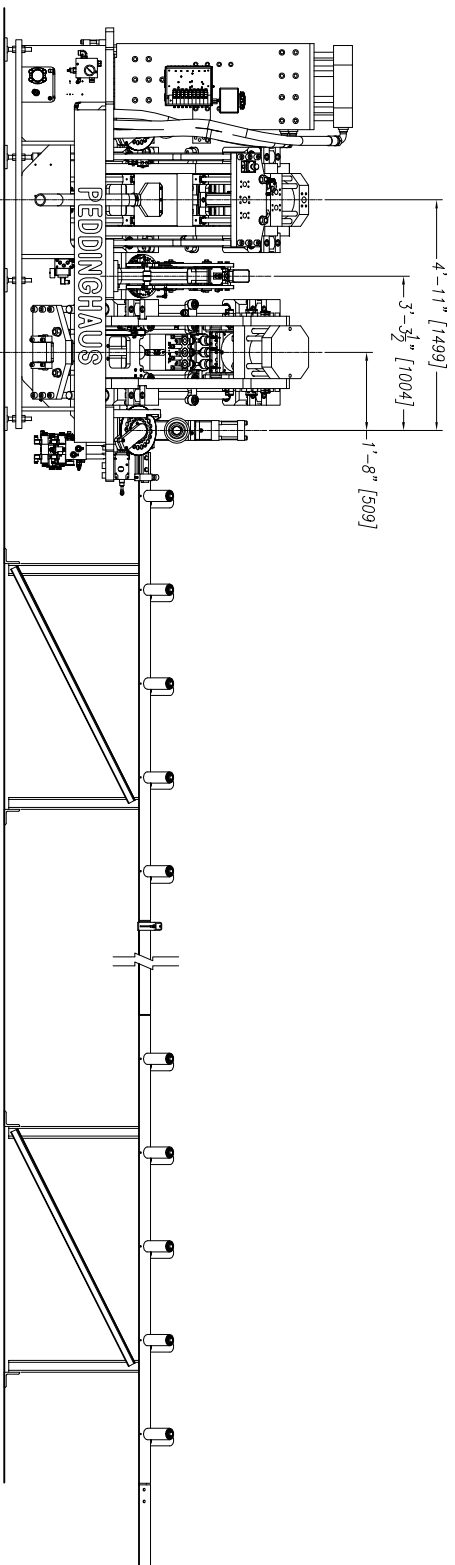
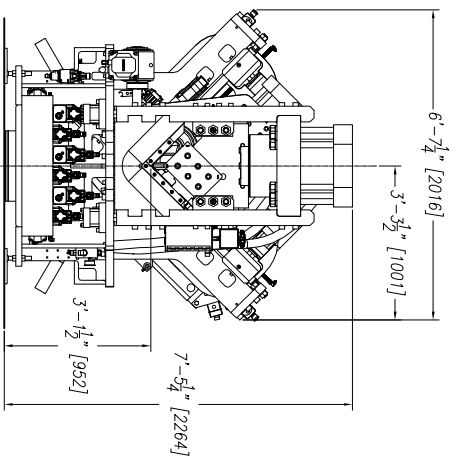
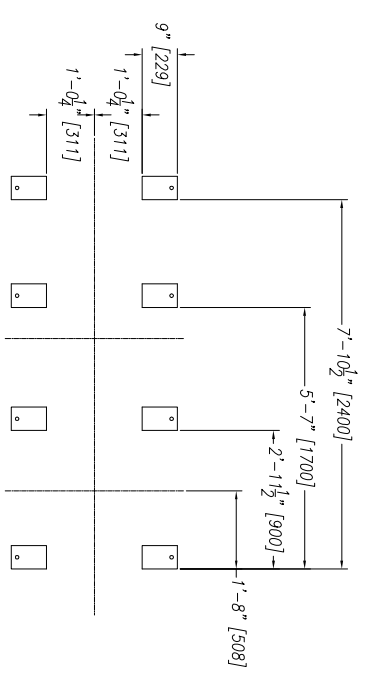
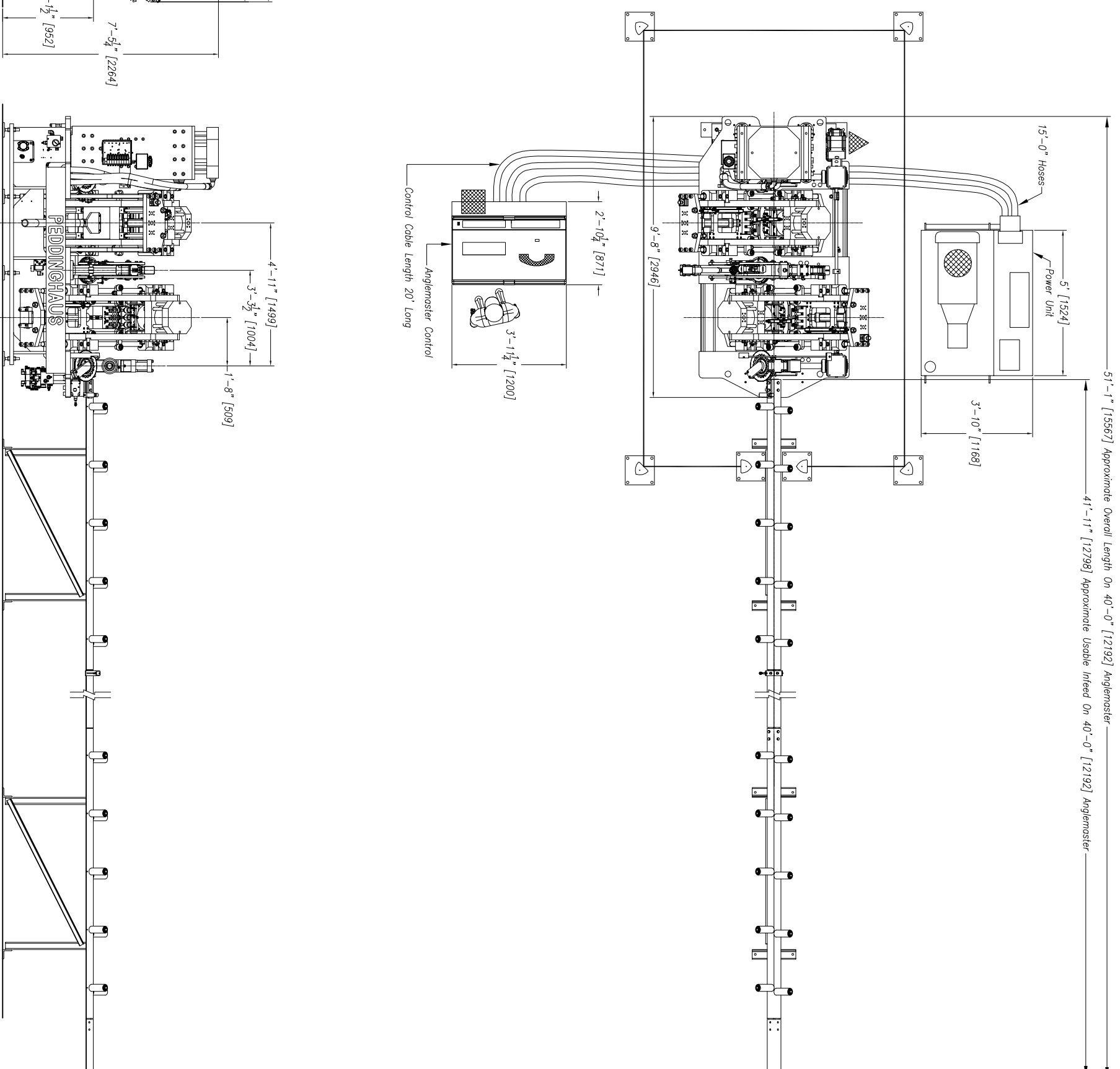

REVISION/C/N #	BY	DATE	DESCRIPTION
E			
D			
C			
B			
A			

**Anglemaster**  
 Peddinghaus Corp.  
 BRADLEY, ILL. U.S.A.  
 AFPS 863 D A Anglemaster  
 For  
 5. Corporation  
 DRAWG. NO.

IMPORTANT SAFETY NOTE:  
 Because of the complexity of this system, the manufacturer assumes full responsibility to prevent access by unauthorized persons and the customer's responsibility to prevent access by unauthorized persons.  
 SCALE: 1/2" = 1' DATE:

THIS PRINT IS THE PROPERTY OF PEDDINGHAUS CORP. AND IS NOT TO BE USED IN ANY MANNER DETRIMENTAL TO THE INTERESTS OF SAID COMPANY.